

Inside video backhaul

Capturing images is the easy part; getting them to where they need to go is the next — and much more challenging — step

By Jasper Bruinzeel

Developments in the surveillance industry continue at an ever-increasing pace. Over the past decade or so, the industry gradually has migrated from analog-based solutions to purely IP-based systems. In a digital, IP-based surveillance solution, as long as a network connection with sufficient bandwidth exists, cameras can be aggregated into an integrated surveillance system, which allows for viewing of camera feeds from multiple locations at a single monitoring site.

Many cities and public-safety organizations have embraced this possibility by upgrading their in-building surveillance systems to IP-based solutions, with additional cameras placed in multiple areas of interest throughout the city, such as downtown areas, high-crime neighborhoods, parking lots and garages, parks, and schools. In designing larger-scale camera surveillance systems, particularly with cameras in multiple locations, a key consideration is how much backhaul capacity is required. Another, of course, is how to provide sufficient backhaul capacity in the most cost-effective manner.

As new IP cameras introduced to the market in recent years have provided increasingly better resolution, the backhaul requirements also have increased due to the growing bandwidth demands of these megapixel cameras. This has further complicated the design of the backhaul network. Also, there are several

options available for providing the backhaul network connection — fiber, Ethernet and wireless. Furthermore, within the wireless category, several choices are available, such as Wi-Fi-based (802.11a/g or 802.11n), WiMAX, microwave and millimeter wave (60/80 GHz).

In this article, we will review the process for selecting cameras, with a specific focus on the choice of camera resolution. Then we will examine encoding schemes and frame-rate considerations, which will have an impact on the bandwidth requirements for the camera network. Once the bandwidth requirements have been determined, the backhaul design can begin. Finally, different backhaul options are reviewed in reference to practical-use scenarios.

First, let's examine the practical value of image resolution. In relation to video surveillance systems, resolution really refers to the number of pixels that is available at the plane of interest to cover a certain object. With more pixels to cover an object of interest, the details about the object can be better identified. Regarding video surveillance, two typical reference applications would be the ability to recognize a face or a license plate. For both, resolution equal to 40 pixels per foot is recommended in order to achieve proper identification.

Before the advent of megapixel camera technology, the industry standard for high-resolution cameras had been 4CIF, or 704x480 pixels. When assuming a resolution goal

of 40 pixels per foot, the coverage width is limited to 17.6 feet. So, when the camera lens is set to 1X zoom, the plane of interest is limited to a distance of 17 feet away from the camera. However, this distance can be increased by using optical zoom, as the angle of view is decreased accordingly. A typical pan-tilt-zoom (PTZ) camera with 35X optical-zoom capability can increase the distance from 17 to 593 feet, while still achieving the goal of 40 pixels per foot at the plane of interest with a coverage width of 17.6 feet. (See Figure 1.)

In recent years, at the cost of added bandwidth, megapixel cameras have been introduced, starting with 1-megapixel and evolving to 5-megapixel devices and beyond. In terms of bandwidth, a 5-megapixel camera requires five times the bandwidth that a 1-megapixel camera requires. But is the 5-megapixel camera also five times more useful or effective? Figure 2 illustrates the improved distance that can be achieved with different cameras in reference to the same goal of 40-pixels-per-foot resolution at the place of interest.

There seems to be a perception that megapixel cameras allow for "digital zoom" on the image almost without limits, and recognize any face in the picture at any distance. Obviously, this is not true. A 5-megapixel camera theoretically can recognize a face at a distance of 61 feet (assuming a lens with 1X zoom), but this pales in comparison to the traditional 4CIF resolution PTZ camera with 35X optical zoom, which can achieve facial recognition at 593 feet. Also, note that the 5-megapixel camera really offers only about twice the number of pixels in the horizontal direction, with a 2X digital-zoom factor, compared to a 1-megapixel camera, which Figure 2 shows. But in terms of bandwidth, remember that five 1-megapixel cameras can be

placed at a certain location for one 5-megapixel camera. Also note that two 1-megapixel cameras placed side-by-side can cover approximately the same horizontal width as one 5-megapixel camera, but will require only 40% of the bandwidth.

Another performance parameter that comes into play when selecting the resolution on a camera is low-light sensitivity. One major drawback of megapixel cameras is the reduced light per sensor, and with that, reduced low-light sensitivity. This issue worsens as the number of pixels increases.

In summary, higher-resolution cameras always will require more bandwidth, but will not necessarily provide better results. It is important to review each surveillance location, and consider the type of camera (fixed or PTZ), low-light requirements, areas of interest, and the required resolution on objects at certain distances from the camera. If possible, try to reduce the overall bandwidth requirement at a location. In some cases, using multiple lower-resolution cameras could provide lower bandwidth requirements and better surveillance results than fewer higher-resolution cameras.

Once a proper camera selection for each of the surveillance locations is made, an estimate of the required bandwidth is possible. But even after selecting the type of camera and resolution, some very important factors still need to be considered that impact the bandwidth numbers. These parameters are frame rate and encoding algorithm.

Cameras generally offer frame rates up to 30 frames per second. As the frame rate is reduced, the motion in the image becomes less smooth, but bandwidth requirements are reduced also. Frame rates between 10 and 15 frames per second generally are still considered “fluid” to an operator. For purposes of this discussion, bandwidth requirements are presented at 12 frames per second for reference purposes.

Also, image compression can be applied to assist in bandwidth reduction. Table 1 shows the bandwidth requirements per camera for different encoding algorithms and image resolutions, based on a typical outdoor surveillance scene and assuming a 30% image compression and a frame rate of 12 frames per second. With this table, it is possible to calculate for each surveillance location what

the backhaul requirements are.

Of these encoding algorithms, H.264 is a fairly recent introduction, but is now commonly available in most leading IP cameras and supported in the video-management solutions. Specifically, when using megapixel cameras, H.264 has been able to bring the bandwidth and storage requirement to manageable numbers.

In designing the backhaul to connect the camera sites with the management server and monitoring system, it makes sense to first consider the possibility of implementing a wired solution. Is a network connection with spare capacity already available to reach a camera site? Or can new cabling be implemented cost effectively? Gigabit Ethernet (GigE) is now commonly available, and provides theoretical speeds of 1 Gbps. Generally providing sufficient bandwidth for most security applications, GigE systems would be a logical choice for any new deployment.

Copper Ethernet wiring (typically Cat-5, Cat-5e, Cat-6 or Cat-7) have a practical length limitation of 100 meters (or about 300 feet) between devices. Another option to consider is the use of power-over-Ethernet

FIGURE 1 OPTICAL ZOOM AND RESOLUTION

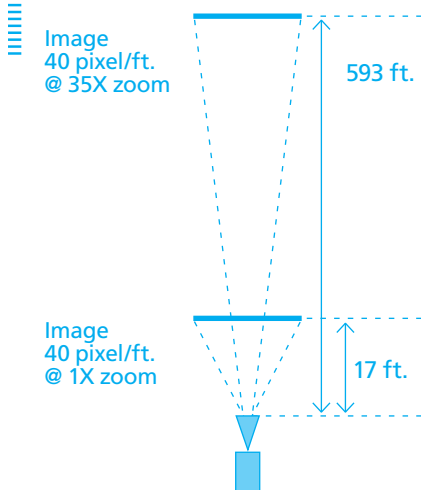

FIGURE 2 IMPROVED REACH WITH MEGAPIXEL DIGITAL ZOOM

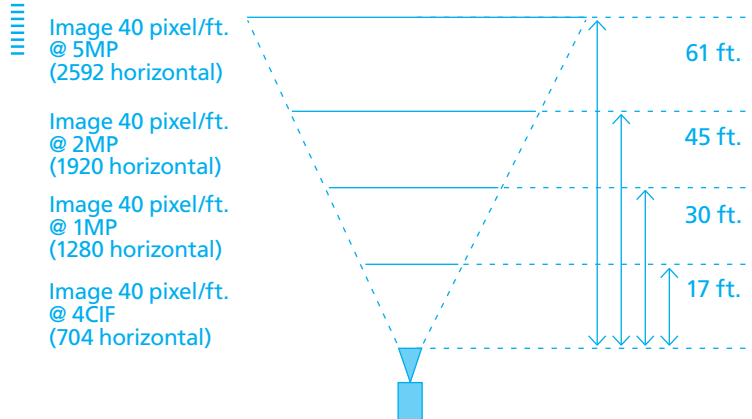

TABLE 1 BANDWIDTH REQUIREMENTS IN MBPS (AT 12 FPS)

RESOLUTION	IMAGE SIZE	TOTAL PIXELS	H.264	MPEG-4	M-JPEG	JPEG2000
CIF	352x240	84,480	0.1	0.3	0.8	0.7
4CIF	704x480	337,920	0.5	1.3	3.0	2.7
D1	720x480	345,600	0.5	1.3	3.1	2.8
1-megapixel	1280x800	1,024,000	1.5	3.9	9.1	8.2
2-megapixel	1920x1080	2,073,600	3.1	8.0	18.4	16.6
5-megapixel	2592x1944	5,038,848	7.5	19.4	44.7	40.3

Note: Assumption of 30% image compression for all compression schemes

TABLE 2 WIRELESS NETWORKING OPTIONS

ARCHITECTURE	TECHNOLOGY	FREQUENCY	SPEED	COST
Clustering	Wi-Fi (11a)	4.9, 5.4 GHz	*	\$
	Wi-Fi (11n)	4.9, 5.4 GHz	**	\$\$
	WiMAX	4.9, 5.4 GHz	**	\$\$
PTP Backhaul	Wi-Fi (11a/n)/WiMAX	4.9, 5.4 GHz	**	\$\$
	Microwave	6, 11, 18, 23 GHz	***	\$\$\$
	Millimeter wave	60, 80 GHz	****	\$\$\$\$

at switch ports, since many fixed IP surveillance cameras allow for a PoE power supply (this is even applicable to some models with outdoor enclosure), resulting in a more cost-effective implementation.

To accommodate longer-length wired network connections, fiber can be used. Most networking products now allow for seamless integration of fiber-based connections, with fiber ports available at switch or router devices. To give an idea of the type of distances that are possible with fiber, single-mode fiber connections enable distances exceeding 10 miles.

For implementations requiring higher-speed networking, 10 Gigabit Ethernet (10GigE) devices are available, but components are more expensive than GigE components.

The problem is that, in citywide type deployments, wired cabling often does not exist, and the cost for

new cable implementations can be very expensive. In those situations, wireless technologies can be reviewed to complete the backhaul design.

In typical camera designs, we can recognize two types of wireless aggregation. First, we can speak of “clustering”, where several sites are connected to one central node. Because only a few camera sites are considered here, bandwidth requirements are relatively low. Both point-to-point and point-to-multipoint wireless architectures are suitable and available. Often, Wi-Fi-based solutions are utilized in camera clusters. Meanwhile, WiMAX solutions slowly are being introduced.

The advantages of WiMAX compared to Wi-Fi are visible primarily in applications involving a larger number of camera sites within a small, contained area. But drawbacks include higher cost and the maximum channel width, which currently

is limited to 10 MHz (in comparison, Wi-Fi technologies support 20 MHz- or 40 MHz-wide channels). Typical throughput is in the 5 to 40 Mbps range, but that will depend on many factors, including technology, channel size and distance.

In regards to spectrum selection, the licensed 4.9 GHz public-safety band is the logical choice. But the spectrum is limited to 50 MHz, and a larger-scale network generally should use 5 MHz- or 10 MHz-wide channels, which would limit to an extent the ability to implement megapixel cameras. When considering the use of unlicensed spectrum, the 2.4 GHz and 5.8 GHz bands generally are very crowded and not suitable. However, the more recently introduced 5.4 GHz band, with 255 MHz of available spectrum, is generally the best bet, and it also enables the use of larger (20 or 40 MHz) channels.

When considering the use of unlicensed spectrum, the 2.4 GHz and 5.8 GHz bands generally are very crowded and not suitable. However, the more recently introduced 5.4 GHz band, with 255 MHz of available spectrum, is generally the best bet, because it enables the use of larger (20 or 40 MHz) channels. Note that both Wi-Fi and WiMAX-based technologies in 4.9 GHz or 5.4 GHz claim the possibility of non-line-of-sight connections (i.e., a connection while an obstruc-

tion is available in the wireless path). Generally, however, the throughput and predictability of the link are severely compromised in such situations. The wireless design should therefore always target line-of-sight connections whenever possible.

For making higher-capacity point-to-point (PTP) backhaul connections, several groups of products are available. In the 4.9 GHz and 5.4 GHz bands, adaptations of Wi-Fi and WiMAX products are available, specialized for PTP connections and offering throughput roughly in a range from 20 to 100 Mbps.

For higher-capacity connections in licensed spectrum, various microwave solutions are available that provide throughput up to several hundreds of Mbps. Typical bands include 6, 11, 18 and 23 GHz. With a variety of antenna sizes, long links can be achieved if required. On the other hand, in the 23 GHz band, highly compact, all-outdoor solutions now are available, with an antenna size of only 1 by 1 foot. Costs also have been reduced in recent years, reducing the obstacle to integrate professional microwave wireless solutions into a wireless camera backhaul design.

For the highest-possible capacity, solutions in the 60 and 80 GHz range offer data rates on the order of 1 Gbps. Propagation characteristics in this band are less advantageous, so link distances are shorter compared to microwave solutions.

In the end, the camera-backhaul design will require a detailed comparison of different options and, possibly, a trade-off of various technologies. In many cases, the ideal backhaul design for a multi-location surveillance solution will use a combination of wired and wireless technologies that are seamlessly integrated into a single, digital, Ethernet-based aggregation network.

The design not only should take into account the needs of the current camera design, but ideally also consider possible future expansions. On the other hand, there generally is a finite budget that needs to be considered in the design. For example, it might turn out that the backhaul net-

work cost to accommodate a targeted camera design is cost prohibitive. In that case, some adjustments to the camera design will be necessary that reduce the backhaul requirements. ■
 Jasper Bruinzeel is vice president of marketing and sales for CelPlan Technologies.

WIRELESS

ENHANCE COMMUNICATIONS WITH NEW WIRELESS SYSTEMS FROM DAVID CLARK

David Clark Wireless Communication Systems provide greater freedom, mobility and safety. Rugged components include wireless gateways and belt stations, along with a variety of wireless headset styles. Ideal for marine, fire/EMS, heavy construction, airline ground support and military applications. Wireless systems are compatible with existing David Clark Company wired intercom systems and with most HF, VHF and UHF radios. Go wireless with David Clark. Call **800-298-6235** or visit **www.davidclark.com**.

See us at IWCE Booth #3070

© 2011 David Clark Company Incorporated

David Clark
 WWW.DAVIDCLARK.COM